

Standard Gears

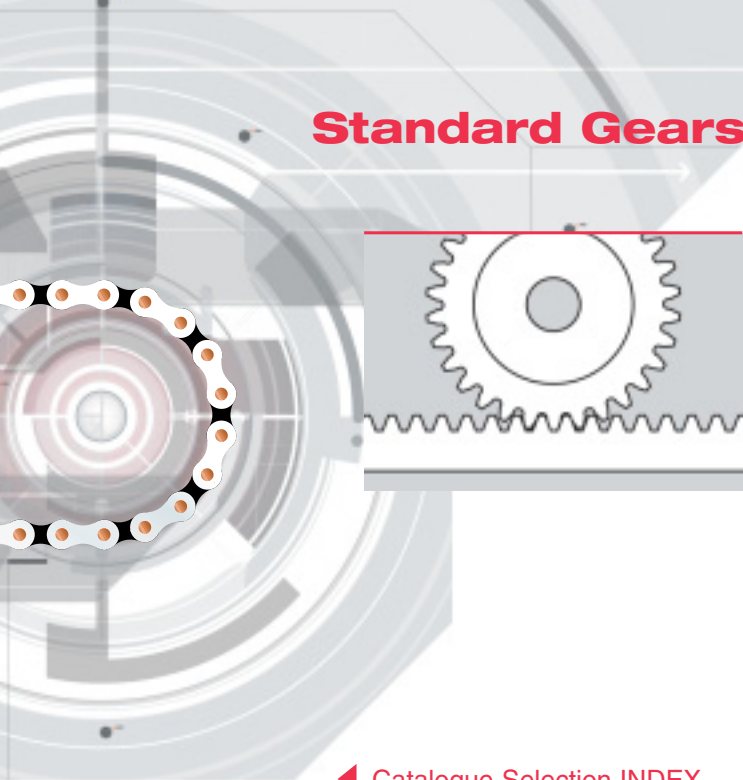

◀ Catalogue Selection INDEX

◀ Enquiry

◀ CD Contents

Index

Gear Products Overview	2	▶
Bevel and Mitre Gear Selection	3-4	▶
D.P. Bevel and Mitre Gears	5	▶
Metric Bevel Gears	7-8	▶
Metric Mitre Gear	6	▶
Straight Racks	13	▶
Spur Gears	10-13	▶
Spur Gear Selection	9	▶



Power Transmission Solutions

Cross+Morse offer a comprehensive range of standard stock gears which, coupled with the capability to supply on short lead times custom designed gears, provides the design engineer with a wide spectrum of solutions from which to select open gear drives.

Standard Stock Gears

The range of standard stock gears is detailed in the following catalogue pages, including recommendations for gear selection, can be summarised as follows:

Bevel and Mitre Gears

Straight Cut Bevel and Mitre Gears manufactured to the Gleason system in medium carbon steels enable simple right angle drives with reduction ratios up to 4:1. Two series of gears are offered, the first the original T.D. Cross range to imperial dimensions from 16DP to 5DP pitch, the second a much improved metric range of gears from 1 Mod. to 5 Mod. pitch. All gears can be induction or flame hardened for longer life under arduous conditions.

Spur Gears

A new range of 20° P.A. spur gears all manufactured in medium carbon steel, provide selection from 1 Mod. through to 6 Mod. pitch with gears from 12 teeth to 127 teeth. All gears have face width equal to ten times Mod. number to provide sensible power transmission capability. To supplement the steel gears is a select range of cast iron wheels covering pitch range 2 Mod. to 5 Mod. with 30 to 60 tooth size.

Straight Racks

Available in standard lengths of 0.5, 1.0 and 2.0 metres is a range of 20° P.A. straight cut racks with pitch range 1 Mod. to 6 Mod. These are designed to combine with the standard spur gears to provide low cost conversion of rotary to linear motion.



Special Custom Made Gear Products

Modification of standard gears by reworking the bore and faces, and adding heat treatment often provides the most economical gear solution; but for those applications where standard gears cannot be used, special gears and racks can be manufactured within the following limits.

Mitre and Bevel Gears

Straight cut gears to the Gleason System up to 250mm diameter, can be provided in a variety of materials.

Spur Gears

In diametrical, circular or module pitches with tooling available most pitch sizes in both 14½° and 20° pressure angle for gears up to 730mm diameter.

Helical Gears

With helix angles up to 45° and pitch diameter up to 710mm.

Straight Racks

Racks of Module or Diametrical (DP) pitches can be supplied up to 2 Metre length and pitch up to 5 Mod or 5 D.P.

Internal Gears and Splines

Hubs up to 635mm can be machined to a depth of 100mm either standard spur gear or internal splines.

Splines and Serrations

Involute, flat root, or fillet root splines and serrations can be cut on machined shafts or customer blanks.

Special Gearboxes

Custom designed gear systems can be supplied to suit individual drive requirements, using spur gears, helical gears, or inverted tooth chain. Shaft centres to 1½ metres and power ratings to 1000KW have been provided. We welcome the opportunity to quote for your requirements.



Bevel and Mitre Gears



Bevel and Mitre Gears are used to transmit power between shafts intersecting at 90°, on low speed, high torque applications where pitch line velocity does not exceed 5 m/s. All Cross+Morse gears are cut to the Gleason System to provide equal strength between pinion and gear.

Interchangeability

Bevel gears of identical pitch and teeth but from different drive ratio gearsets are not interchangeable. All bevel gears are generated on the pitch cone radius which varies with the ratio of gears within a given diametral pitch.

Installation

All mitre and bevel gears develop end thrust which must be counteracted by bearings of adequate capacity. Accurate and rigid mounting of both gear and pinion provide quiet operation and long life. Bearing spacing and shaft stiffness should be selected to keep shaft deflection below .025mm.

Lubrication

Grease lubrication can be adequate for low speed applications but oil splash lubrication is always preferable. The oil level should cover the face of the lower gear, and sufficient capacity should be available to keep oil temperature below 95°C.

Efficiency

When correctly aligned, a bevel gearset with oil lubrication can operate with transmission efficiency up to 98 per cent.

Power Rating Tables - Standard Metric Mitre Gears

Gear Set Catalogue No.	Gear Speed R.P.M.													
	10	50	100	200	300	400	500	600	800	1000	1200	1500	2000	3000
M1016	.001	.003	.005	.010	.014	.018	.021	.025	.030	.037	.044	.052	.063	.085
M1019	.001	.005	.009	.016	.023	.029	.034	.040	.049	.060	.070	.083	.100	.137
M1022	.002	.008	.015	.026	.037	.046	.055	.066	.079	.097	.114	.135	.164	.222
M1026	.004	.014	.025	.044	.062	.078	.093	.110	.133	.163	.192	.227	.275	.374
M1030	.006	.021	.038	.069	.096	.121	.145	.171	.206	.253	.298	.352	.427	.580
M1516	.003	.010	.017	.031	.044	.055	.066	.078	.094	.115	.136	.161	.195	.264
M1519	.005	.017	.030	.055	.077	.097	.115	.136	.164	.201	.237	.280	.340	.462
M1522	.007	.027	.048	.085	.119	.150	.179	.211	.255	.313	.368	.435	.528	.717
M1526	.012	.043	.078	.139	.195	.215	.293	.346	.417	.512	.603	.712	.863	1.172
M1530	.019	.069	.123	.220	.308	.387	.462	.545	.657	.806	.950	1.122	1.361	1.848
M2016	.006	.022	.039	.070	.099	.124	.148	.175	.210	.258	.304	.359	.436	.592
M2019	.010	.038	.068	.121	.169	.212	.253	.299	.360	.442	.521	.616	.747	1.014
M2022	.016	.060	.107	.191	.267	.336	.401	.474	.570	.700	.825	.974	1.182	1.605
M2026	.028	.101	.180	.322	.451	.567	.676	.799	.962	1.181	1.392	1.643	1.993	2.706
M2030	.042	.152	.272	.485	.680	.854	1.019	1.204	1.450	1.780	2.097	2.475	3.003	4.077
M2516	0.01	0.04	0.07	0.13	0.18	0.23	0.27	0.33	0.39	0.48	0.57	0.67	0.81	1.10
M2519	0.02	0.07	0.12	0.22	0.31	0.39	0.47	0.55	0.66	0.81	0.96	1.14	1.38	1.87
M2522	0.03	0.11	0.19	0.35	0.49	0.61	0.73	0.86	1.04	1.28	1.50	1.78	2.15	2.93
M2526	0.05	0.19	0.33	0.60	0.84	1.05	1.26	1.48	1.79	2.20	2.59	3.06	3.71	5.00
M2530	0.07	0.28	0.50	0.89	1.25	1.58	1.88	2.23	2.68	3.29	3.88	4.58	5.55	7.40
M3016	0.02	0.07	0.12	0.22	0.30	0.38	0.46	0.54	0.65	0.80	0.95	1.12	1.35	1.84
M3019	0.03	0.11	0.21	0.37	0.51	0.65	0.77	0.91	1.10	1.35	1.59	1.88	2.28	3.10
M3022	0.05	0.18	0.33	0.59	0.83	1.05	1.25	1.47	1.77	2.18	2.57	3.03	3.68	5.00
M3026	0.08	0.30	0.54	0.97	1.36	1.71	2.04	2.41	2.90	3.56	4.20	4.96	6.01	8.00
M3030	0.13	0.46	0.83	1.48	2.08	2.62	3.12	3.69	4.44	5.45	6.42	7.58	9.20	12.40
M3516	0.03	0.10	0.19	0.34	0.47	0.59	0.71	0.84	1.01	1.24	1.46	1.72	2.09	2.84
M3519	0.05	0.17	0.31	0.56	0.79	0.99	1.18	1.40	1.69	2.07	2.44	2.88	3.49	4.60
M3522	0.07	0.28	0.50	.090	1.26	1.58	1.89	2.23	2.69	3.30	3.89	4.59	5.57	7.40
M3526	0.13	0.47	0.84	1.50	2.10	2.64	3.15	3.73	4.49	5.51	6.49	7.66	9.30	12.40
M3530	0.20	0.73	1.31	2.34	3.27	4.11	4.91	5.80	6.98	8.57	10.10	11.92	14.40	19.20
M4016	0.04	0.15	0.26	0.47	0.66	0.83	1.00	1.18	1.42	1.74	2.05	2.42	2.94	4.00
M4019	0.07	0.26	0.47	0.84	1.18	1.48	1.76	2.09	2.51	3.08	3.63	4.29	5.20	7.00
M4022	0.11	0.41	0.74	1.33	1.86	2.34	2.79	3.29	3.97	4.87	5.74	6.77	8.22	11.00
M4026	0.20	0.72	1.28	2.29	3.20	4.03	4.80	5.67	6.83	8.39	9.89	11.67	14.40	19.20
M4030	0.29	1.06	1.89	3.38	4.73	5.95	7.10	8.38	10.10	12.40	14.60	17.24	21.20	28.40
M4516	0.06	0.21	0.37	0.67	0.94	1.18	1.41	1.67	2.01	2.47	2.91	3.44	4.17	5.60
M4519	0.10	0.36	0.65	1.16	1.63	2.04	2.44	2.88	3.47	4.26	5.02	5.93	7.19	9.60
M4522	0.16	0.57	1.02	1.83	2.56	3.21	3.84	4.53	5.46	6.70	7.90	9.32	11.40	15.20
M4526	0.26	0.93	1.67	2.99	4.19	5.26	6.28	7.42	8.93	10.97	12.92	15.25	19.20	25.60
M4530	0.40	1.46	2.62	4.67	6.54	8.22	9.81	11.59	13.96	17.14	20.19	24.00	30.40	40.80
M5016	0.07	0.27	0.48	0.87	1.22	1.53	1.83	2.16	2.60	3.19	3.76	4.44	5.39	7.20
M5019	0.13	0.48	0.87	1.55	2.17	2.73	3.26	3.85	4.63	5.69	6.70	7.92	9.11	12.00
M5022	0.21	0.76	1.36	2.43	3.40	4.27	5.10	6.02	7.25	8.90	10.49	12.38	15.20	20.00
M5026	0.35	1.29	2.30	4.12	5.76	7.24	8.64	10.21	12.30	15.09	17.78	21.20	27.20	36.00
M5030	0.54	1.96	3.50	6.25	8.75	11.00	13.13	15.51	18.67	22.93	27.01	32.00	40.80	54.40

Selections in tinted area have pitch line velocity over 5 m/s. For these selections it is recommended teeth are induction hardened.

Design and Selection

The power steel bevel gears can transmit under ideal lubrication conditions is normally limited by wear life. The following tables give design power in kW for a normal operating life of 10,000 hours for stock gears. For increased life gears can be induction hardened.

For correct selection of a Bevel Gearset first assemble application data, including Power, shaft speeds and drive ratio required.

- From details of Driver and Driven equipment select correct Service Factor from table below.
- Calculate Design Power kW
Design Power = Actual Power × Service factor.
- If Drive ratio not available determine from
Ratio = $\frac{\text{R.P.M. High Speed Shaft}}{\text{R.P.M. Low Speed Shaft}}$
- From table for Drive Ratio (i.e. 1:1 Mitre Gear, 1.5:1 to 4:1 Bevel Gears), select smallest gearset where Power equals or exceeds Design power at Pinion R.P.M. For variable speed drives check selection at max. shaft speed, torque and power.

For useful formulae on Bevel Gears design refer to appendix pages.

Design Factors

Power Source	Character of Load of Driven Equipment		
	Uniform	Moderate Shock	Heavy Shock
Uniform	1.00	1.25	1.75
Light Impulse	1.25	1.50	2.00
Heavy Impulse	1.50	1.75	2.25

For speed increase drives add 0.1 to above factors.

Bevel and Mitre Gears



Power Rating Tables - Standard Metric Bevel Gears

Gear Set Catalogue No.	Gear Speed R.P.M.													
	10	50	100	200	300	400	500	600	800	1000	1200	1500	2000	3000
1.5:1 Ratio - Standard Metric Bevel Gears														
M101624	.001	.004	.007	.013	.019	.024	.028	.033	.040	.050	.058	.069	.084	.114
M151624	.004	.014	.026	.047	.065	.083	.098	.116	.140	.172	.203	.239	.290	.394
M201624	.009	.032	.057	.102	.143	.179	.214	.253	.305	.374	.441	.520	.631	.857
M251624	.017	.061	.108	.194	.272	.342	.407	.481	.579	.711	.838	.989	1.200	1.630
M301624	.027	.098	.175	.313	.438	.550	.657	.776	.934	1.147	1.351	1.595	1.935	2.627
M351624	.043	.155	.277	.495	.694	.872	1.040	1.229	1.480	1.817	2.140	2.527	3.065	4.162
M401624	.058	.211	.377	.674	.944	1.186	1.415	1.672	2.013	2.472	2.912	3.438	4.171	5.663
M451624	.080	.292	.521	.931	1.304	1.639	1.956	2.310	2.782	3.415	4.023	4.750	5.762	
M501624	.113	.408	.729	1.302	1.823	2.292	2.734	3.229	3.889	4.775	5.625	6.641	8.056	
2.0:1 Ratio - Standard Metric Bevel Gears														
M101530	.001	.004	.008	.015	.021	.026	.031	.036	.044	.054	.064	.075	.091	.124
M151530	.004	.016	.028	.050	.071	.089	.106	.125	.151	.185	.218	.257	.312	.424
M201530	.009	.035	.062	.110	.155	.195	.232	.274	.330	.406	.478	.564	.685	.930
M251530	.018	.066	.118	.211	.295	.371	.442	.532	.629	.773	.910	1.075	1.304	1.771
M301530	.029	.107	.191	.342	.479	.602	.718	.848	1.022	1.254	1.478	1.745	2.116	2.874
M351530	.046	.168	.300	.535	.750	.942	1.124	1.328	1.599	1.963	2.313	2.713	3.313	4.498
M401530	.066	.239	.427	.763	1.069	1.344	1.603	1.893	2.280	2.800	3.298	3.894	4.723	6.413
M451530	.093	.336	.601	1.074	1.504	1.890	2.255	2.664	3.208	3.939	4.640	5.478	6.645	
M501530	.127	.460	.822	1.468	2.056	2.585	3.084	3.642	4.386	5.385	6.344	7.490	9.085	
3.0:1 Ratio - Standard Metric Bevel Gears														
M101545	.002	.007	.013	.023	.033	.040	.048	.057	.069	.084	.098	.117	.142	.193
M151545	.006	.022	.040	.071	.099	.125	.149	.176	.212	.260	.307	.362	.440	.597
M201545	.013	.049	.089	.158	.222	.279	.331	.393	.473	.582	.685	.809	.981	1.332
M251545	.026	.094	.168	.300	.421	.529	.631	.746	.898	1.103	1.299	1.534	1.860	2.526
M301545	.043	.154	.276	.494	.691	.869	1.037	1.224	1.474	1.810	2.132	2.517	3.054	4.147
M351545	.064	.232	.415	.741	1.038	1.305	1.557	1.839	2.214	2.718	3.203	3.781	4.587	6.227
M401545	.095	.342	.612	1.093	1.530	1.923	2.294	2.709	3.263	4.006	4.720	5.572	6.759	9.178
M451545	.125	.452	.809	1.445	2.023	2.543	3.034	3.583	4.316	5.298	6.242	7.370	8.940	
M501545	.172	.624	1.115	1.992	2.789	3.506	4.184	4.940	5.950	7.305	8.605	10.160	12.325	
4.0:1 Ratio - Standard Metric Bevel Gears														
M101560	.002	.009	.017	.031	.043	.055	.065	.077	.092	.114	.134	.158	.192	.261
M151560	.007	.026	.046	.083	.116	.146	.175	.206	.248	.305	.359	.424	.515	.698
M201560	.017	.062	.110	.197	.276	.347	.414	.489	.589	.723	.852	1.005	1.220	1.656
M251560	.031	.111	.199	.356	.498	.626	.748	.883	1.063	1.305	1.538	1.816	2.203	2.991
M301560	.051	.187	.334	.597	.836	1.050	1.254	1.480	1.783	2.189	2.579	3.045	3.693	5.015
M351560	.078	.282	.504	.900	1.260	1.584	1.890	2.232	2.688	3.300	3.888	4.590	5.569	7.561
M401560	.114	.412	.736	1.315	1.842	2.315	2.763	3.263	3.929	4.824	5.684	6.709	8.139	11.050
M451560	.152	.553	.988	1.764	2.470	3.105	3.705	4.375	5.270	6.470	7.620	9.000	10.915	
M501560	.199	.719	1.285	2.295	3.210	4.040	4.820	5.690	6.855	8.415	9.920	11.700	14.200	

Power Rating Tables - Imperial Series D.P. Stock Bevel and Mitre Gears

Gear Set Catalogue No.	Pinion Speed R.P.M.													
	10	50	100	200	300	400	500	600	800	1000	1200	1500	2000	3000
Mitre Gears - D.P. Standard														
1618	.005	.020	.035	.064	.089	.112	.134	.158	.190	.233	.275	.325	.394	.535
1218	.012	.045	.081	.145	.203	.255	.304	.359	.433	.531	.626	.739	.897	1.218
1224	.029	.107	.191	.341	.478	.601	.717	.847	1.020	1.252	1.475	1.742	2.113	2.870
1024	.052	.188	.336	.600	.840	1.056	1.261	1.489	1.793	2.201	2.593	3.062	3.714	5.043
824	.098	.353	.632	1.128	1.580	1.986	2.370	2.800	3.370	4.135	4.875	5.750	6.980	
624	.216	.780	1.395	2.490	3.490	4.385	5.230	6.180	7.440	9.130	10.760	12.710		
524	.350	1.265	2.260	4.040	5.650	7.110	8.480	10.20	12.060	14.810	17.450	20.600		
2:1 Ratio - Standard D.P. Gears														
161530	.005	.019	.034	.060	.084	.106	.126	.149	.180	.221	.260	.307	.372	.506
121530	.013	.046	.083	.148	.207	.260	.311	.367	.442	.542	.639	.755	.916	1.294
101530	.022	.079	.140	.251	.352	.442	.527	.623	.750	.921	1.085	1.281	1.554	2.110
81530	.041	.149	.266	.476	.666	.837	.999	1.180	1.421	1.745	2.056	2.427	2.944	4.000
61530	.094	.338	.605	1.080	1.511	1.900	2.267	2.677	3.225	3.959	4.664	5.506	6.680	9.070
3:1 Ratio - Standard D.P. Gears														
161236	.004	.015	.026	.047	.066	.083	.099	.117	.141	.173	.204	.241	.292	.397
121236	.008	.030	.055	.098	.137	.172	.206	.243	.293	.359	.423	.500	.606	.823
101236	.015	.056	.100	.180	.252	.317	.378	.446	.537	.659	.777	.917	1.113	1.511
81236	.028	.103	.184	.329	.461	.580	.692	.817	.984	1.208	1.423	1.680	2.038	2.767
61236	.064	.231	.421	.737	1.031	1.296	1.547	1.827	2.200	2.701	3.182	3.757	4.558	6.188

Selections in tinted area have pitch line velocity over 5 m/s. For these selections it is recommended teeth are induction hardened.

Tel +44 121 360 0155

Fax +44 121 325 1079

Email sales@crossmorse.com

Standard D.P. Mitre and Bevel Gears



Standard D.P. Mitre Gears
All gears cut 20° pressure angle
material - 080M40

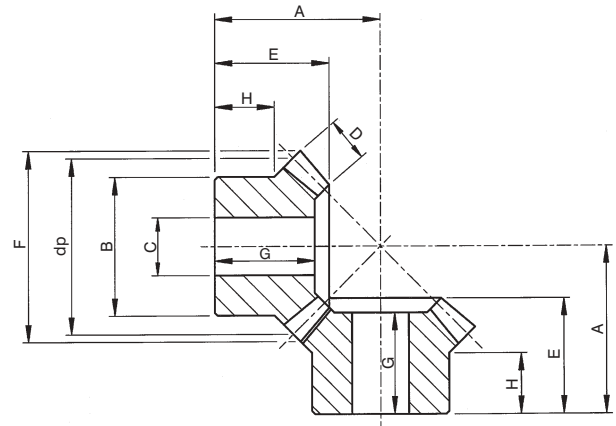

Imperial Series Mitre Gears 16 D.P. to 5 D.P.

Catalogue No.	D.P.	No. of Teeth	Pitch Dia. dp	A	B	C		D	E	F	G	H	Approx Wt. per Gear kg
						Min	Max						
1618	16	18	28.57	26.19	22.2	7.94	12	7.9	18.0	30.7	16.5	8.7	0.05
1218	12	18	38.10	34.92	31.7	9.52	16	11.1	24.4	41.1	22.1	12.7	0.12
1224	12	24	50.80	47.62	41.3	12.70	23	12.7	32.0	53.8	29.7	17.5	0.30
1024	10	24	60.96	53.97	50.8	15.87	27	17.5	36.8	64.5	34.3	18.4	0.50
824	8	24	76.20	69.85	50.8	15.87	32	22.2	48.5	80.8	45.5	19.1	0.86
624	6	24	101.60	88.90	66.7	25.40	44	28.6	59.9	107.7	55.1	20.6	1.84
524	5	24	121.92	101.60	76.2	31.75	51	31.7	65.0	129.0	58.9	17.8	2.88

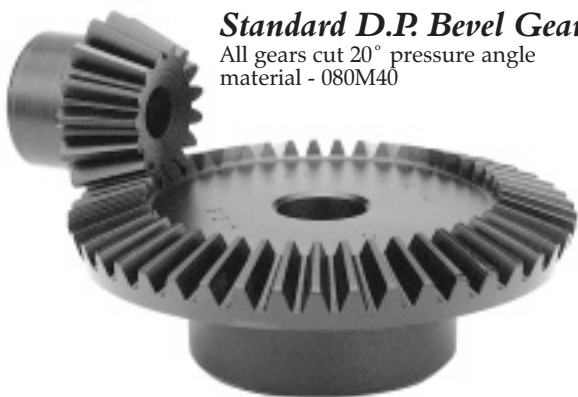

Standard D.P. Bevel Gears
All gears cut 20° pressure angle
material - 080M40

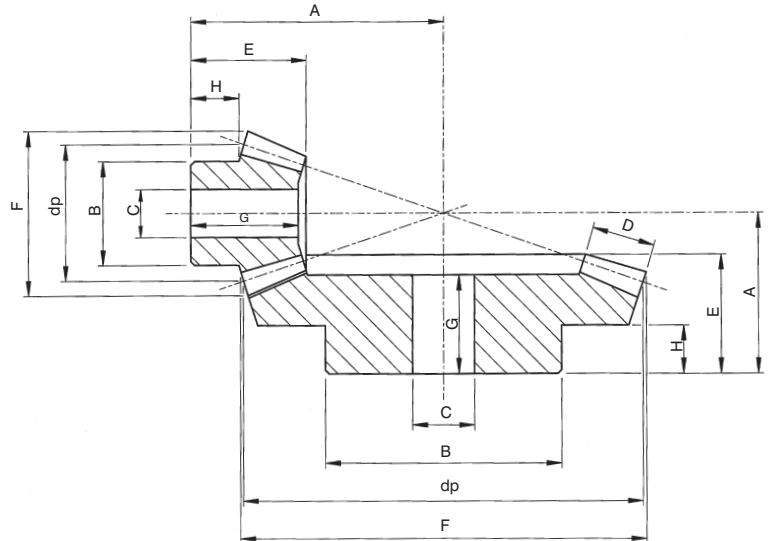

Imperial Series Bevel Gears 16 D.P. to 6 D.P.

Catalogue No.	D.P.	No. of Teeth	Pitch Dia. dp	A	B	C		D	E	F	G	H	Approx Wt. per Gear kg
						Min	Max						
Bevel Gear Sets 2:1 Ratio													
161530	16	15 30	23.80 47.62	34.92 25.40	17.5 34.9	7.94 9.52	11 24	7.9 7.9	18.8 17.5	27.7 48.5	17.5 15.5	9.3 7.2	0.04 0.14
121530	12	15 30	31.75 63.50	43.66 33.33	25.4 42.9	9.52 12.70	15 28	12.7 12.7	23.9 23.9	36.8 64.8	22.1 21.1	10.3 9.3	0.08 0.31
101530	10	15 30	38.10 76.20	50.80 38.10	28.6 44.5	9.52 12.70	17 29	15.8 15.8	27.7 26.9	44.2 77.7	25.1 23.4	10.3 10.3	0.14 0.48
81530	8	15 30	47.62 95.25	63.50 57.15	34.9 60.3	12.70 15.87	22 40	20.6 20.6	35.3 43.4	55.4 97.0	32.8 39.4	12.3 17.6	0.27 1.26
61530	6	15 30	63.50 127.00	85.72 73.12	44.5 79.4	19.05 19.05	28 53	28.6 28.6	49.0 55.1	73.7 129.5	45.5 49.8	17.8 21.9	0.60 2.94
Bevel Gear Sets 3:1 Ratio													
161236	16	12 36	19.05 57.15	38.10 25.40	14.3 38.1	7.94 12.70	9 26	9.5 9.5	19.1 19.6	23.4 57.7	19.1 16.2	9.8 6.3	0.02 0.22
121236	12	12 36	25.40 76.20	50.80 31.75	19.1 50.8	9.52 12.70	11 34	11.1 11.1	23.9 23.4	31.0 77.0	23.9 19.3	11.6 10.3	0.05 0.44
101236	10	12 36	30.48 91.44	57.15 44.45	25.4 57.2	9.52 14.29	14 38	15.8 15.8	27.2 35.1	37.3 92.5	27.2 30.2	10.6 12.7	0.05 1.02
81236	8	12 36	38.10 114.30	71.44 44.45	31.7 76.2	12.70 15.87	18 50	19.1 19.1	33.3 32.5	46.5 115.6	33.3 26.2	13.2 12.7	0.19 1.44
61236	6	12 36	50.80 152.40	101.60 63.50	41.3 95.3	19.05 25.40	24 63	25.4 25.4	50.8 47.7	62.2 153.9	50.8 40.4	23.8 19.1	0.45 3.64

All Gears Stocked with Standard Plain Bore. Rebore, Keyway, Setscrew and Induction Hardening Services available.
Bevel and Mitre Gears with other D.P. and Module can be supplied to order up to 375mm diameter.

Standard Metric Mitre Gears



Cross+Morse standard stock metric mitre gears complement the existing range of diametral pitch gears to provide the designer a wider range of selection. The mitre gear sets are available in 5 tooth sizes in 9 pitches from 1.0 Mod to 5.0 Mod, providing the correct solution for right angle drives in applications from light instrumentation and office equipment to heavy manufacturing machinery.

All gears are manufactured in medium carbon steels for high strength and durability, and can be optionally induction/flame hardened for more arduous applications. The gears are cut to the Gleason System with 20 degree pressure angle, and supplied only in pairs to ensure correct matching.

For long life and efficient operation it is essential that mitre gears are correctly mounted on rigidly supported shafts with bearings able to support the axial and radial loads imposed. The shafts should be at a true right angle within the following tolerances:-

Shaft Axis to intersect within $\pm 0.025\text{mm}$

Shafts to be at right angles within $\pm 5'$ angle

The mounting distance (Dimension 'A') to be true within $+0.0/-0.05\text{mm}$

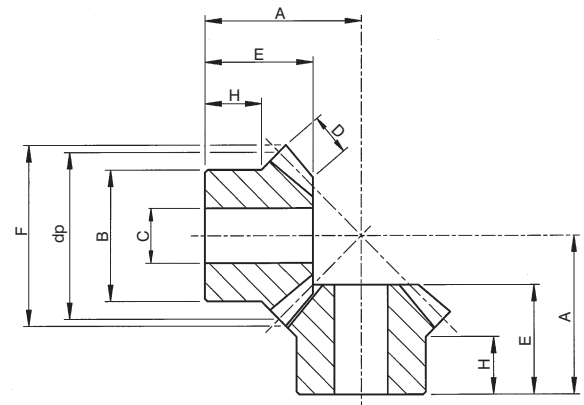

Cat. No.	Pitch Module	No. Teeth	dp	A	B	Bore C		D	E	F	H	Approx Weight per Gear Kg
						min	max					
M1016	1	16	16.0	16	13.3	4	7.5	4	11.2	17.4	6.5	.013
M1019		19	19.0	18	15.3	4	9	4	11.8	20.4	6.5	.015
M1022		22	22.0	20	16.3	5	10	4.7	12.8	23.4	6.5	.022
M1026		26	26.0	22	20.3	5	13	5.5	13.3	27.4	7	.033
M1030		30	30.0	26	20.3	5	13	6.4	16.0	31.4	8	.080
M1516	1.5	16	24.0	26	20.3	8	10	6	18.9	26.1	12	.028
M1519		19	28.5	30	20.3	8	12.5	6	21.3	30.6	12	.050
M1522		22	33.0	33	25.3	8	16	7.5	22.5	35.1	12	.081
M1526		26	39.0	36	28.3	8	19	8.5	23.2	41.1	12	.117
M1530		30	45.0	42	30.3	12	20	10	27.2	47.1	12	.167
M2016	2	16	32.0	33	25.3	8	14	8	23.5	34.8	14	.070
M2019		19	38.0	36	25.3	8	16	9	24.2	40.8	12	.105
M2022		22	44.0	42	30.3	12	20	10	27.9	46.8	14	.158
M2026		26	52.0	48	35.3	12	24	12	31.4	54.8	14	.261
M2030		30	60.0	54	40.3	14	27	13	34.1	62.8	17	.385
M2516	2.5	16	40.0	40	30.3	12	18	10	28.1	43.5	15	.150
M2519		19	47.5	42	35.3	12	23	11	27.1	51.0	13	.200
M2522		22	55.0	48	45.3	16	28	12	30.1	58.5	16	.328
M2526		26	65.0	54	45.3	16	30	15	33.2	68.5	16	.490
M2530		30	75.0	64	50.3	16	34	16	39.0	78.5	20	.700
M3016	3	16	48.0	45	40.3	12	21	12	31.7	52.5	18	.250
M3019		19	57.0	54	40.3	14	27	13	36.0	61.2	17	.370
M3022		22	66.0	58	50.3	16	34	15	36.9	70.2	17	.540
M3026		26	78.0	64	50.3	16	34	17	38.4	82.2	18	.750
M3030		30	90.0	74	60.3	20	40	19	43.8	94.2	22	.950
M3516	3.5	16	56.0	53	45.3	16	24	14	36.4	60.9	20	.450
M3519		19	66.5	58.8	50.3	18	34	15	37.8	71.5	19	.650
M3522		22	77.0	64	55.3	20	36	17	39.1	81.9	18	.720
M3526		26	91.0	73.05	62.3	20	41	20	43.35	96.0	20	1.290
M3530		30	105.0	82	70.3	20	46	23	47.1	110.0	22	1.900
M4016	4	16	64.0	64	50.3	16	31	15	44.3	69.7	25	0.680
M4019		19	76.0	68	55.3	20	36	18	44.4	81.7	22	0.900
M4022		22	88.0	74	60.3	20	40	20	45.9	93.7	22	1.050
M4026		26	104.0	82	70.3	20	46	25	48.0	109.7	22	2.000
M4030		30	120.0	94	80.3	20	54	26	54.2	125.7	25	2.450
M4516	4.5	16	72.0	68	55.3	20	34	17.5	46.3	78.4	25	0.750
M4519		19	85.5	75.57	62.3	20	41	20	49	91.8	25	1.290
M4522		22	99.0	82	70.3	20	46	22	50.1	105.3	25	1.550
M4526		26	117.0	93.3	75.3	20	50	25	54.7	123.0	26	2.790
M4530		30	135.0	105	80.3	20	54	29	60	141.4	28	3.100
M5016	5	16	80.0	74	60.3	20	40	18	48.9	87.1	25	0.920
M5019		19	95.0	82	60.3	20	40	22	52.2	102.1	25	1.500
M5022		22	110.0	94	80.3	20	54	24	58.2	117.1	30	2.390
M5026		26	130.0	105	80.3	20	54	29	62.7	137.1	30	3.140
M5030		30	150.0	119	80.3	20	54	32	68.9	157.1	35	4.200

All dimensions in mm.

All gears stocked with standard plain bore. Rebore, keyway, setscrew and induction hardening services available.

Bevel and mitre gears with other D.P. and module can be supplied to order up to 375mm diameter.

Tel +44 121 360 0155

Fax +44 121 325 1079

Email sales@crossmorse.com

Standard Metric Series Bevel Gears



Cross+Morse standard stock bevel gears complement the existing range of diametral pitch gears to provide the designer a wider range of selection. Available in 4 standard ratios with 9 different pitches ranging from 1.0 Mod to 5.0 Mod, these bevels provide the ideal solution for many right angle drive applications from light instrumentation to rugged manufacturing plant and agricultural equipment.

All gears are manufactured in medium carbon steels for high strength and durability, and can be optionally induction/flame hardened for more arduous applications. The gears are all gear cut to the Gleason System with 20 degree pressure angle, and supplied only in complete sets to ensure correct matching.

For long life and efficient operation it is essential that bevel gears are correctly mounted on rigidly supported shafts with bearings able to support the axial and radial loads imposed. The shafts should be at a true right angle within the following tolerances:-
Shaft Axis to intersect within $\pm 0.025\text{mm}$

Shafts to be at right angles within $\pm 5'$ angle

The mounting distance (Dimension 'A') to be true within $+0.0/-0.05\text{mm}$

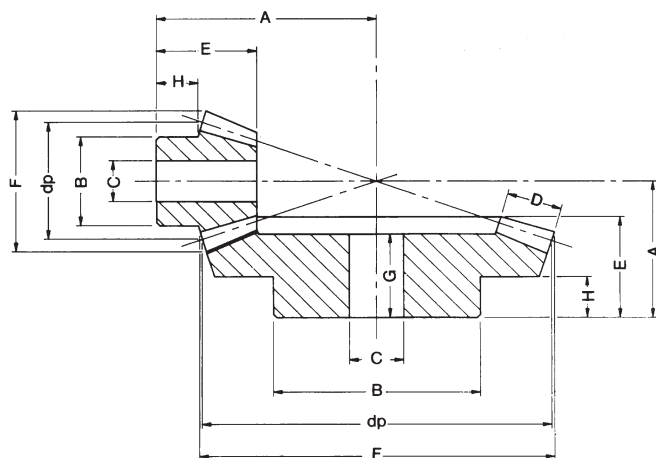

Metric Series Bevel Gears 1.0 Mod to 5.0 Mod

Catalogue No.	Pitch Module	No. Teeth	Pitch Dia. dp	A	B	Bore C		D	E	F	G	H	Approx Wt. kg
						min	max						
Bevel Gear Sets 1.5 : 1 Ratio													
M101624	1	16 24	16.0 24.0	20 20	13.3 20.3	4 5	8 12	4.3 4.3	12.0 14.8	18.1 24.8	12.0 13.3	7.0 9.3	.012 .035
M151624	1.5	16 24	24.0 36.0	31 32	20.3 28.3	8 8	10 13	8 8	20.3 24.9	27.1 37.2	20.3 22.7	11.8 16.0	.040 .115
M201624	2	16 24	32.0 48.0	40 37	25.3 32.3	8 8	15 21	10 10	25.2 27.2	36.2 49.7	25.2 24.7	13.8 16.0	.080 .255
M251624	2.5	16 24	40.0 60.0	49 46	32.3 45.3	12 16	18 29	13 13	30.8 34.0	45.2 62.1	30.8 30.8	16.4 20.0	.17 .40
M301624	3	16 24	48.0 72.0	55 51	40.3 55.3	12 16	23 36	14.5 14.5	32.4 36.2	54.3 74.5	32.4 32.0	16.4 20.0	.30 .65
M351624	3.5	16 24	56.0 84.0	66 61	45.3 55.3	16 20	26 36	18 18	40.4 44.2	63.3 86.9	40.4 40.0	20.4 25.0	.57 .90
M401624	4	16 24	64.0 96.0	78 66	50.3 60.3	16 20	32 40	18 18	46.8 45.5	72.4 99.3	46.8 40.0	25.4 25.0	.68 1.20
M451624	4.5	16 24	72.0 108.0	83 81	60.3 80.3	20 20	38 54	20 20	47.6 57.8	81.4 111.7	47.6 51.3	25.1 35.0	.93 2.20
M501624	5	16 24	80.0 120.0	92 86	60.3 80.3	20 20	40 54	24 24	54.1 61.1	90.5 124.1	54.1 54.5	25.4 35.0	1.06 2.40
Bevel Gear Sets 2.0 : 1 Ratio													
M101530	1	15 30	15.0 30.0	22 20	13.3 20.3	4 5	8 13	5 5	11.9 15.1	17.4 30.6	11.9 13.7	6.5 9.0	.010 .040
M151530	1.5	15 30	22.5 45.0	35 32	19.3 32.3	8 8	10 21	9 9	21.1 25.2	26.1 45.9	21.1 23.0	11.9 16.0	.040 .170
M201530	2	15 30	30.0 60.0	45 39	25.3 40.3	8 14	13 27	11.5 11.5	26.0 29.8	34.8 61.2	26.0 26.8	14.1 18.0	.090 .320
M251530	2.5	15 30	37.5 75.0	55 45	32.3 45.3	12 16	17 30	15 15	31.8 33.7	43.5 76.5	31.8 30.0	16.2 20.0	.170 .500
M301530	3	15 30	45.0 90.0	66 56	40.3 55.3	12 16	22 36	17 17	37.3 42.1	52.2 91.8	37.3 38.0	19.9 25.0	.315 .960
M351530	3.5	15 30	52.5 105.0	79 61	45.3 60.3	16 20	25 40	20.5 20.5	46.1 45.0	60.9 107.1	46.1 40.0	24.7 25.0	.49 1.35
M401530	4	15 30	60.0 120.0	87 76	50.3 80.3	20 20	30 54	22.5 22.5	48.6 57.3	69.6 122.3	48.6 51.9	24.6 35.0	.63 2.45
M451530	4.5	15 30	67.5 135.0	94 81	60.3 80.3	20 20	34 54	26 26	51.4 60.3	78.3 137.6	51.4 54.3	24.7 35.0	1.20 3.18
M501530	5	15 30	75.0 150.0	104 85	60.3 80.3	20 20	37 54	30 30	57.6 62.5	87.0 152.9	57.6 56.0	25.3 35.0	1.38 3.87

All dimensions in mm.

All gears stocked with standard plain bore. Rebore, keyway, setscrew and induction hardening services available. Bevel and mitre gears with other D.P. and module can be supplied to order up to 375mm diameter.

Tel +44 121 360 0155

Fax +44 121 325 1079

Email sales@crossmorse.com

Standard Metric Bevel Gears



Tel +44 121 360 0155

Fax +44 121 325 1079

Email sales@crossmorse.com

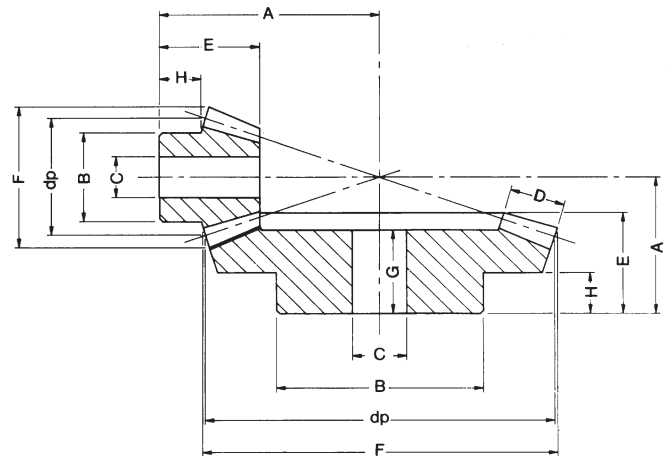

Metric Series Bevel Gears 1.0 Mod to 5.0 Mod

Catalogue No.	Pitch Module	No. Teeth	Pitch Dia. dp	A	B	Bore C		D	E	F	G	H	Approx Wt. kg
						min	max						
Bevel Gear Sets 3 : 1 Ratio													
M101545	1	15 45	15.0 45.0	32 22	13.3 25.3	4 8	8 16	7.1 7.1	16.6 17.1	17.7 45.3	16.6 15.2	9.2 10.0	.015 .10
M151545	1.5	15 45	22.5 67.5	46 37	19.3 45.3	8 14	10 30	10.5 10.5	22.6 29.6	26.5 68.1	22.6 34.6	11.7 20.0	.045 .41
M201545	2	15 45	30.0 90.0	60 42	25.3 45.3	8 16	15 30	14 14	28.9 32.1	35.4 90.8	28.9 28.4	14.2 20.0	.085 .61
M251545	2.5	15 45	37.5 112.5	73 52	32.3 60.3	12 20	18 40	18 18	34.6 39.7	44.2 113.4	34.6 35.3	15.9 25.0	.13 1.22
M301545	3	15 45	45.0 135.0	88 62	40.3 60.3	16 20	22 40	21 21	41.3 47.2	53.0 136.1	41.3 42.0	19.7 30.0	.34 1.85
M351545	3.5	15 45	52.5 157.5	105 72	45.3 80.3	20 20	28 54	23.5 23.5	49.6 54.4	61.9 158.8	49.6 48.6	25.0 35.0	.70 3.25
M401545	4	15 45	60.0 180.0	117 77	50.3 80.3	20 20	32 54	27.5 27.5	54.3 57.0	70.7 181.5	54.3 50.5	25.4 35.0	.75 3.95
M451545	4.5	15 45	67.5 202.5	128 87	55.3 90.3	20 20	36 60	28.5 28.5	55.2 63.9	79.5 204.2	55.2 57.0	24.8 40.0	.87 5.60
M501545	5	15 45	75.0 225.0	145 92	60.3 90.3	20 20	40 60	33 33	65.3 66.7	88.4 226.9	65.3 59.2	30.0 40.0	1.35 7.05
Bevel Gear Sets 4 : 1 Ratio													
M101560	1	15 60	15.0 60.0	38 22	13.3 30.3	4 8	8 20	9.3 9.3	17.2 17.1	17.80 60.30	17.2 15.2	7.7 10	.015 .24
M151560	1.5	15 60	22.5 90.0	57 42	20.3 50.3	8 16	11 34	11 11	23.0 34.0	26.70 90.40	23.0 31.2	11.7 25	.031 .78
M201560	2	15 60	30.0 120.0	75 48	25.3 60.3	8 16	14 40	16 16	31.0 37.6	35.60 120.60	31.0 34.2	14.4 25	.12 1.30
M251560	2.5	15 60	37.5 150.0	94 58	32.3 60.3	14 20	20 40	19 19	38.1 44.8	44.50 150.70	38.1 40.0	18.4 30	.21 1.95
M301560	3	15 60	45.0 180.0	115 69	40.3 80.3	16 20	24 54	23 23	48.1 53.2	53.30 180.80	48.1 48.2	24.5 35	.40 3.65
M351560	3.5	15 60	52.5 210.0	131 79	45.3 90.3	20 20	30 60	26 26	52.1 60.4	62.60 211.00	52.1 54.4	25.1 40	.56 5.40
M401560	4	15 60	60.0 240.0	145 82	50.3 90.3	20 20	34 60	30 30	55.1 60.8	71.10 241.10	55.1 53.0	23 40	.79 6.20
M451560	4.5	15 60	67.5 270.0	159.9 86.3	52.3 90.3	20 20	35 60	32 32	57.0 62.0	79.97 271.24	57.0 53.5	23 40	1.08 7.95
M501560	5	15 60	75.0 300.0	177.7 92	55.3 90.3	20 20	36 60	34 34	62.0 65.0	88.80 301.30	62.0 55.0	25 40	1.40 10.30

All dimensions in mm.

All gears stocked with standard plain bore. Rebore, keyway, setscrew and induction hardening services available.

Bevel and mitre gears with other D.P. and module can be supplied to order up to 375mm diameter.

Spur Gear Selection



For a required centre distance and gear ratio a suitable pair of spur gears can be selected used and assessed by the following procedure.

Select numbers of teeth in gears and module (pitch).

$$\text{Gear Ratio } i = \frac{Z_2 \text{ (Teeth driven gear)}}{Z_1 \text{ (Teeth driven gear)}}$$

$$\begin{aligned} \text{Shaft centre distance in mm} &= \text{sum gear teeth} \times \text{pitch} \\ &= (Z_1 + Z_2) P \end{aligned}$$

From this initial selection each gear can be assessed for strength and wear using the following formulae. The least of the four calculated powers is the capacity of the gear set. The capacity required is determined by multiplying actual power by a service factor relative to driver and driven equipment, refer page c2. If calculated power is below required capacity increase pitch or face width of gears, adjust teeth sizes accordingly, and reassess drive. If calculated power is substantially in excess of required capacity a lower Module could be considered.

$$\text{Strength capacity } P_s = \frac{X_b \times S_b \times Y_s \times F \times N \times Z \times P^2 \text{ kw}}{19,100 \times 10^3}$$

$$\text{Wear capacity } P_w = \frac{X_c \times S_c \times Y_z \times F \times N \times Z \times P^{1.8} \text{kw}}{10,000 \times 10^3}$$

- Where:-
- F = Face width mm
 - N = Gear shaft speed r.p.m.
 - P = Gear pitch, Module No.
 - S_b = Bending stress for gear material (see below)
 - S_c = Surface stress for gear material (see below)
 - X_b = Speed factor for strength - see table 1
 - X_c = Speed factor for wear - see table 2
 - Y_s = Strength factor - see table 3
 - Y_z = Zone factor - see table 4

Factors S_b and S_c Gears

Gear Type	S _b N/mm ²	S _c N/mm ²
Steel Gears and racks	130	9.65
Cast Gears	52	9.30

Table 1 Speed factor for Strength X_b (for 26000 hour rating)

Daily Hours	Gear Shaft rpm																
	0.1	1	5	10	40	100	150	200	400	500	600	1000	1500	2000	3000	5000	10000
24	0.784	0.640	0.565	0.518	0.435	0.375	0.349	0.330	0.294	0.286	0.274	0.246	0.223	0.211	0.180	0.153	0.122
12	0.865	0.700	0.623	0.568	0.475	0.420	0.384	0.362	0.321	0.310	0.300	0.268	0.245	0.231	0.198	0.167	0.134
6	0.970	0.775	0.685	0.628	0.526	0.460	0.426	0.410	0.357	0.342	0.331	0.297	0.272	0.263	0.221	0.186	0.147
3	1.060	0.864	0.750	0.690	0.580	0.512	0.474	0.448	0.401	0.380	0.368	0.328	0.301	0.286	0.245	0.207	0.164
1	1.250	1.031	0.880	0.800	0.678	0.596	0.552	0.525	0.465	0.445	0.437	0.385	0.349	0.328	0.286	0.240	0.192

Table 2 Combined Speed Factor for Wear X_c (for 26000 hour rating)

Daily Hours	Gear Shaft rpm																
	0.1	1	5	10	40	100	150	200	400	500	600	1000	1500	2000	3000	5000	10000
24	1.149	0.780	0.564	0.488	0.377	0.320	0.297	0.282	0.250	0.240	0.233	0.209	0.192	0.180	0.157	0.132	0.106
12	1.448	0.998	0.718	0.625	0.478	0.408	0.372	0.355	0.317	0.304	0.294	0.262	0.240	0.226	0.196	0.165	0.132
6	1.830	1.258	0.901	0.790	0.607	0.514	0.474	0.455	0.404	0.382	0.370	0.334	0.307	0.287	0.250	0.211	0.167
3	2.200	1.570	1.168	0.980	0.762	0.650	0.602	0.575	0.508	0.480	0.472	0.425	0.381	0.360	0.308	0.263	0.210
1	3.320	2.280	1.653	1.440	1.218	0.928	0.862	0.825	0.728	0.700	0.675	0.610	0.551	0.520	0.425	0.390	0.304

Table 3 Strength Factor Y_s

No. Teeth	Number Teeth Mating Gear																						
	Rack	127	100	80	70	60	50	40	35	30	28	26	24	22	20	19	18	17	16	15	14	13	12
12	.658	.625	.618	.614	.610	.605	.600	.597	.596	.593	.592	.591	.590	.588	.585	.584	.581	.578	.575	.573	.571	.567	.562
13	.679	.644	.638	.632	.628	.623	.616	.612	.610	.606	.605	.604	.602	.600	.597	.597	.595	.590	.587	.584	.578	.575	.570
14	.700	.662	.655	.650	.645	.640	.632	.626	.623	.620	.619	.617	.614	.611	.608	.606	.604	.600	.597	.592	.588	.585	.576
15	.714	.678	.670	.664	.659	.653	.646	.638	.635	.631	.629	.626	.624	.620	.617	.613	.609	.606	.598	.598	.593	.587	.580
16	.729	.690	.684	.676	.672	.665	.657	.650	.647	.639	.637	.634	.630	.626	.621	.617	.615	.610	.606	.601	.596	.593	.590
17	.740	.702	.696	.687	.682	.675	.665	.657	.653	.647	.643	.639	.634	.630	.624	.620	.616	.613	.609	.604	.598	.592	.584
18	.750	.710	.704	.697	.691	.683	.672	.665	.660	.650	.645	.642	.637	.632	.625	.622	.618	.614	.610	.605	.600	.593	.584
19	.760	.720	.713	.706	.700	.692	.680	.672	.664	.652	.647	.643	.638	.633	.623	.623	.619	.615	.610	.605	.600	.593	.584
20	.770	.728	.720	.713	.707	.698	.686	.677	.665	.652	.646	.642	.638	.628	.626	.622	.619	.614	.610	.605	.600	.586	.579
22	.786	.740	.732	.726	.714	.709	.696	.674	.660	.647	.644	.640	.635	.630	.624	.621	.617	.613	.608	.604	.598	.590	.581
24	.800	.752	.741	.735	.728	.718	.700	.667	.648	.641	.637	.634	.629	.625	.620	.617	.613	.610	.605	.600	.593	.586	.577
26	.813	.762	.753	.742	.735	.725	.699	.671	.645	.633	.630	.627	.623	.619	.614	.612	.609	.605	.601	.595	.589	.581	.572
28	.828	.772	.763	.750	.743	.732	.711	.675	.647	.625	.622	.620	.616	.613	.609	.607	.603	.600	.594	.588	.582	.575	.566
30	.838	.782	.772	.759	.750	.738	.716	.677	.649	.623	.615	.611	.609	.605	.602	.600	.596	.591	.587	.582	.576	.569	.560
35	.862	.800	.789	.775	.765	.751	.727	.686	.654	.622	.613	.600	.592	.588	.584	.581	.578	.574	.570	.564	.554	.546	.536
40	.876	.820	.803	.788	.776	.761	.736	.693	.660	.642	.619	.607	.594	.585	.574	.569	.565	.562	.559	.555	.550	.544	.535
50	.900	.842	.822	.806	.794	.776	.752	.705	.675	.644	.633	.620	.604	.593	.582	.575	.568	.560	.552	.544	.538	.528	.517
60	.913	.850	.833	.815	.802	.783	.758	.716	.686	.654	.642	.630	.615	.600	.590	.583	.574	.567	.559	.549	.542	.533	.523
70	.923	.858	.839	.820	.806	.788	.762	.723	.695	.664	.650	.638	.624	.611	.596	.589	.582	.574	.566	.556	.547	.539	.529
80	.928	.860	.839	.821	.808	.791	.765	.728	.703	.673	.658	.645	.632	.618	.602	.596	.588	.571	.562	.553	.543	.533	.523
100	.931	.860	.840	.822	.809	.793	.767	.734	.710	.683	.669	.661	.641	.628	.613	.604	.596	.589	.580	.571	.561	.550	.541
127	.930	.860	.836	.820	.808	.789	.770	.738	.716	.693	.680	.670	.650	.638	.624	.616	.608	.598	.590	.580	.570	.560	.550
Rack	-	.839	.820	.808	.800	.780	.767	.735	.742	.728	.721	.714	.705	.696	.684	.677	.669	.661	.652	.642	.632	.620	.606

Table 4 Zone Factor Y_z (Note: factor same for both gears in gearset)

No. Teeth	Number Teeth Mating Gear																						
	Rack	127	100	80	70	60	50	40	35	30	28	26	24	22	20	19	18	17	16	15	14	13	12
12	1.47	1.35	1.34	1.32	1.30	1.28	1.26	1.25	1.25	1.24	1.23	1.22	1.21	1.20	1.19	1.18	1.16	1.14	1.12	1.10	1.07	1.04	1.01
13	1.65	1.47	1.46	1.44	1.42	1.39	1.35	1.34	1.32	1.31	1.29	1.28	1.26	1.25	1.23	1.20	1.18	1.16	1.14	1.12	1.09	1.06	1.04
14	1.75	1.61	1.59	1.55	1.53	1.49	1.45	1.42	1.40	1.38	1.37	1.36	1.34	1.32	1.29	1.28	1.25	1.23	1.21	1.18	1.15	1.09	1.07
15	1.90	1.72	1.69	1.64	1.61	1.58	1.53	1.48	1.46	1.43	1.42	1.41	1.39	1.37	1.34	1.31	1.29	1.27	1.24	1.21	1.18	1.12	1.10
16	2.08	1.84	1.80	1.75	1.72	1.67	1.62	1.55	1.53	1.49	1.48	1.46	1.45	1.42	1.39	1.36	1.33	1.30	1.28	1.24	1.21	1.14	1.12
17	2.20	1.97	1.92	1.86	1.81	1.75	1.68	1.61	1.59	1.55	1.54	1.52	1.49	1.47	1.43	1.41	1.38	1.35	1.30	1.27	1.23	1.16	1.14
18	2.30	2.06	2.01	1.94	1.89	1.83	1.75	1.66	1.63	1.60	1.58	1.56	1.53	1.50	1.46	1.44	1.41	1.38	1.33	1.29	1.25	1.18	1.16
19	2.42	2.16	2.10	2.04	1.98	1.92	1.82	1.71	1.68	1.64	1.62	1.60	1.57	1.54	1.50	1.47	1.44	1.41	1.36	1.31	1.28	1.20	1.18
20	2.55	2.26	2.20	2.12	2.07	2.00	1.89	1.75	1.72	1.68	1.66	1.63	1.60	1.56	1.53	1.50	1.46	1.43	1.39	1.34	1.29	1.23	1.19
22	2.78	2.42	2.35	2.28	2.22	2.13	2.00	1.88	1.82	1.75	1.73	1.70	1.66	1.62	1.56	1.54	1.50	1.47	1.42	1.37	1.32	1.25	1.20
24	3.00	2.59	2.50	2.42	2.34	2.25	2.13	1.98	1.90	1.83	1.79	1.75	1.71	1.66	1.60	1.57	1.53	1.49	1.45	1.39	1.34	1.26	1.21
26	3.20	2.74	2.64	2.53	2.44	2.36	2.23	2.06	1.96	1.88	1.84	1.80	1.75	1.70	1.63	1.60	1.56	1.52	1.46	1.41	1.36	1.28	1.22
28	3.45	2.89	2.79	2.66	2.56	2.46	2.33	2.15	2.04	1.94	1.90	1.84	1.79	1.73	1.66	1.62	1.58	1.54	1.48	1.42	1.37	1.29	1.23
30	3.70	3.03	2.90	2.76	2.67	2.54	2.40	2.30	2.11	1.98	1.94	1.88	1.83	1.75	1.68	1.64	1.60	1.55	1.49	1.43	1.38	1.31	1.24
35	4.30	3.44	3.35	3.30	3.20	2.89	2.77	2.60	2.40	2.27	2.11	2.04	1.96	1.90	1.82	1.72	1.68	1.63	1.59	1.53	1.46	1.40	1.32
40	4.65	3.64	3.50	3.27	3.11	2.93	2.76	2.53	2.40	2.30	2.15	2.06	1.98	1.88	1.75	1.71	1.66	1.61	1.55	1.48	1.42	1.34	1.25
50	5.50	4.07	3.84	3.65																			

Standard Spur Gears



Dimensions tables for Spur Gears 1.0 and 1.5 Mod.

All gears machined from medium carbon, induction hardening steels.



Gear Widths

Pitch	A	B
1 Mod	25	15
1.5 Mod	30	17

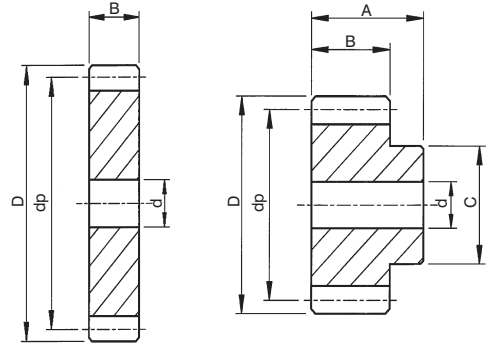

1.0 Mod Spur Gears

Suffix of Cat. No. indicates gear type

Gear Type 'A'

Gear Type 'B'

Cat. No.	No. Teeth	Pitch Dia. dp	Min Bore d	Max. Bore	Hub C	Outside Dia. D	Weight kg	Cat. No.	No. Teeth	Pitch Dia. dp	Min Bore d	Max. Bore	Hub C	Outside Dia. D	Weight kg
S1012B	12	12	-	6	9	14	.012	S1048B	48	48	10	20	30	50	0.26
S1013B	13	13	-	7	10	15	.016	S1049B	49	49	10	20	30	51	0.27
S1014B	14	14	-	7	10	16	.020	S1050B	50	50	12	20	30	52	0.28
S1015B	15	15	-	8	12	17	.025	S1051B	51	51	12	27	40	53	0.31
S1016B	16	16	-	8	13	18	.030	S1052B	52	52	12	27	40	54	0.32
S1017B	17	17	8	9	14	19	.033	S1053B	53	53	12	27	40	55	0.34
S1018B	18	18	8	10	15	20	.038	S1054B	54	54	12	27	40	56	0.35
S1019B	19	19	8	10	15	21	.045	S1055B	55	55	12	27	40	57	0.36
S1020B	20	20	8	11	16	22	.055	S1056B	56	56	12	27	40	58	0.37
S1021B	21	21	8	11	16	23	.058	S1057B	57	57	12	27	40	59	0.38
S1022B	22	22	8	12	18	24	.060	S1058B	58	58	12	27	40	60	0.39
S1023B	23	23	8	12	18	25	.065	S1059B	59	59	12	27	40	61	0.40
S1024B	24	24	8	13	20	26	.070	S1060B	60	60	12	27	40	62	0.41
S1025B	25	25	8	13	20	27	.075	S1061B	61	61	12	34	50	63	0.47
S1026B	26	26	8	13	20	28	.085	S1062B	62	62	12	34	50	64	0.48
S1027B	27	27	8	13	20	29	.090	S1063B	63	63	12	34	50	65	0.49
S1028B	28	28	8	13	20	30	.095	S1064B	64	64	12	34	50	66	0.50
S1029B	29	29	8	13	20	31	.100	S1065B	65	65	12	34	50	67	0.51
S1030B	30	30	8	13	20	32	.105	S1066B	66	66	12	34	50	68	0.52
S1031B	31	31	10	16	25	33	.110	S1067B	67	67	12	34	50	69	0.53
S1032B	32	32	10	16	25	34	.120	S1068B	68	68	12	34	50	70	0.54
S1033B	33	33	10	16	25	35	.130	S1069B	69	69	12	34	50	71	0.55
S1034B	34	34	10	16	25	36	.135	S1070B	70	70	12	34	50	72	0.56
S1035B	35	35	10	16	25	37	.140	S1072A	72	72	12	45	-	74	0.43
S1036B	36	36	10	16	25	38	.150	S1075A	75	75	12	46	-	77	0.46
S1037B	37	37	10	16	25	39	.155	S1076A	76	76	12	46	-	78	0.52
S1038B	38	38	10	16	25	40	.160	S1080A	80	80	12	50	-	82	0.55
S1039B	39	39	10	16	25	41	.170	S1085A	85	85	12	54	-	87	0.62
S1040B	40	40	10	16	25	42	.180	S1090A	90	90	12	57	-	92	0.70
S1041B	41	41	10	20	30	43	.190	S1095A	95	95	12	60	-	97	0.80
S1042B	42	42	10	20	30	44	.200	S10100A	100	100	12	62	-	102	0.90
S1043B	43	43	10	20	30	45	.210	S10110A	110	110	12	68	-	112	1.12
S1044B	44	44	10	20	30	46	.220	S10114A	114	114	12	70	-	116	1.20
S1045B	45	45	10	20	30	47	.230	S10120A	120	120	12	74	-	122	1.25
S1046B	46	46	10	20	30	48	.240	S10127A	127	127	12	80	-	129	1.49
S1047B	47	47	10	20	30	49	.250								

1.5 Mod Spur Gears

Cat. No.	No. Teeth	Pitch Dia. dp	Min Bore d	Max. Bore	Hub C	Outside Dia. D	Weight kg	Cat. No.	No. Teeth	Pitch Dia. dp	Min Bore d	Max. Bore	Hub C	Outside Dia. D	Weight kg
S1512B	12	18.0	8	9	14	21.0	.03	S1548B	48	72.0	14	34	50	75.0	0.70
S1513B	13	19.5	8	9	14	22.5	.04	S1549B	49	73.5	14	34	50	76.5	0.72
S1514B	14	21.0	8	12	18	24.0	.06	S1550B	50	75.0	14	34	50	78.0	0.75
S1515B	15	22.5	8	12	18	25.5	.07	S1551B	51	76.5	15	40	60	79.5	0.86
S1516B	16	24.0	8	13	20	27.0	.08	S1552B	52	78.0	15	40	60	81.0	0.87
S1517B	17	25.5	8	13	20	28.5	.09	S1553B	53	79.5	15	40	60	82.5	0.89
S1518B	18	27.0	8	13	20	30.0	.10	S1554B	54	81.0	15	40	60	84.0	0.91
S1519B	19	28.5	8	13	20	31.5	.11	S1555B	55	82.5	15	40	60	85.5	0.93
S1520B	20	30.0	8	16	25	33.0	.13	S1556B	56	84.0	15	40	60	87.0	0.95
S1521B	21	31.5	10	16	25	34.5	.14	S1557B	57	85.5	15	40	60	88.5	0.97
S1522B	22	33.0	10	16	25	36.0	.15	S1558B	58	87.0	15	40	60	90.0	1.00
S1523B	23	34.5	10	16	25	37.5	.17	S1559B	59	88.5	15	40	60	91.5	1.05
S1524B	24	36.0	10	16	25	39.0	.18	S1560B	60	90.0	15	40	60	93.0	1.10
S1525B	25	37.5	10	16	25	40.5	.19	S1561B	61	91.5	20	46	70	94.5	1.20
S1526B	26	39.0	12	20	30	42.0	.20	S1562B	62	93.0	20	46	70	96.0	1.23
S1527B	27	40.5	12	20	30	43.5	.21	S1563B	63	94.5	20	46	70	97.5	1.25
S1528B	28	42.0	12	20	30	45.0	.22	S1564B	64	96.0	20	46	70	99.0	1.27
S1529B	29	43.5	12	20	30	46.5	.23	S1565B	65	97.5	20	46	70	100.5	1.30
S1530B	30	45.0	12	20	30	48.0	.25	S1566B	66	99.0	20	46	70	102.0	1.35
S1531B	31	46.5	12	24	35	49.5	.27	S1567B	67	100.5	20	46	70	103.5	1.38
S1532B	32	48.0	12	24	35	51.0	.28	S1568B	68	102.0	20	46	70	105.0	1.42
S1533B	33	49.5	12	24	35	52.5	.30	S1569B	69	103.5	20	46	70	106.5	1.45
S1534B	34	51.0	12	24	35	54.0	.32	S1570B	70	105.0	20	46	70	108.0	1.48
S1535B	35	52.5	12	24	35	55.5	.34	S1572A	72	108.0	20	65	-	111.0	1.18
S1536B	36	54.0	12	24	35	57.0	.36	S1575A	75	112.5	20	68	-	115.5	1.28
S1537B	37	55.5	12	27	40	58.5	.38	S1576A	76	114.0	20	68	-	117.0	1.32
S1538B	38	57.0	12	27	40	60.0	.40	S1580A	80	120.0	20	72	-	123.0	1.45
S1539B	39	58.5	12	27	40	61.5	.42	S1585A	85	127.5	20	80	-	130.5	1.60
S1540B	40	60.0	12	27	40	63.0	.45	S1590A	90	135.0	20	85	-	138.0	1.85
S1541B	41	61.5	14	34	50	64.5	.52	S1595A	95	142.5	20	90	-	145.5	2.04
S1542B	42	63.0	14	34	50	66.0	.55	S15100A	100	150.0	20	95	-	153.0	2.30
S1543B	43	64.5	14	34	50	67.5	.57	S15110A	110	165.0	20	105	-	168.0	2.81
S1544B	44	66.0	14	34	50	69.0	.60	S15114A	114	171.0	20	107	-	174.0	3.30
S1545B	45	67.5	14	34	50	70.5	.62	S15120A	120	180.0	20	115	-	183.0	3.39
S1546B	46	69.0	14	34	50	72.0	.65	S15127A	127	190.5	20	120	-	193.5	3.78
S1547B	47	70.5	14	34	50	73.5	.68								

Tel +44 121 360 0155 Fax +44 121 325 1079

Email sales@crossmorse.com

Standard Spur Gears



Dimensions tables for Spur Gears 2.0 to 6.0 Mod.

All gears machined from medium carbon steels.



Gear Widths mm

Pitch	A	B
2 Mod	35	20
2.5 Mod	40	25
3 Mod	50	30
4 Mod	60	40
5 Mod	75	50
6 Mod	80	60

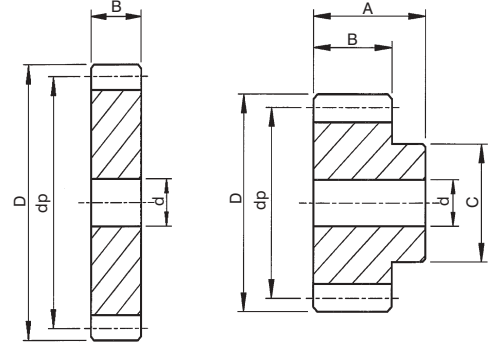

Gear Type 'A' Gear Type 'B'

2.0 Mod Spur Gears

Suffix of Cat. No. indicates gear type

Cat. No.	No. Teeth	Pitch Dia. dp	Min Bore d	Max. Bore	Hub C	Outside Dia. D	Weight kg	Cat. No.	No. Teeth	Pitch Dia. dp	Min Bore d	Max. Bore	Hub C	Outside Dia. D	Weight kg
S2012B	12	24	10	12	18	28	.08	S2048B	48	96	16	46	70	100	1.40
S2013B	13	26	10	12	19	30	.10	S2049B	49	98	16	46	70	102	1.47
S2014B	14	28	10	13	20	32	.12	S2050B	50	100	16	46	70	104	1.55
S2015B	15	30	10	14	22	34	.14	S2051B	51	102	20	46	70	106	1.60
S2016B	16	32	10	15	24	36	.15	S2052B	52	104	20	46	70	108	1.65
S2017B	17	34	10	16	25	38	.16	S2053B	53	106	20	46	70	110	1.70
S2018B	18	36	10	16	25	40	.17	S2054B	54	108	20	46	70	112	1.75
S2019B	19	38	10	16	25	42	.19	S2055B	55	110	20	46	70	114	1.80
S2020B	20	40	10	20	30	44	.24	S2056B	56	112	20	46	70	116	1.87
S2021B	21	42	12	20	30	46	.25	S2057B	57	114	20	46	70	118	1.94
S2022B	22	44	12	20	30	48	.27	S2058B	58	116	20	46	70	120	2.00
S2023B	23	46	12	20	30	50	.29	S2059B	59	118	20	46	70	122	2.07
S2024B	24	48	12	24	35	52	.33	S2060B	60	120	20	46	70	124	2.15
S2025B	25	50	12	24	35	54	.36	S2061B	61	122	20	54	80	126	2.25
S2026B	26	52	12	27	40	56	.41	S2062B	62	124	20	54	80	128	2.30
S2027B	27	54	12	27	40	58	.45	S2063B	63	126	20	54	80	130	2.35
S2028B	28	56	12	27	40	60	.48	S2064B	64	128	20	54	80	132	2.40
S2029B	29	58	14	27	40	62	.51	S2065B	65	130	20	54	80	134	2.45
S2030B	30	60	14	27	40	64	.54	S2066B	66	132	20	54	80	136	2.60
S2031B	31	62	14	30	45	66	.60	S2067B	67	134	20	54	80	138	2.67
S2032B	32	64	14	30	45	68	.63	S2068B	68	136	20	54	80	140	2.74
S2033B	33	66	14	30	45	70	.66	S2069B	69	138	20	54	80	142	2.82
S2034B	34	68	14	30	45	72	.69	S2070B	70	140	20	54	80	144	2.90
S2035B	35	70	14	30	45	74	.72	S2072A	72	144	20	90	-	148	2.53
S2036B	36	72	14	30	45	76	.76	S2075A	75	150	20	94	-	154	2.72
S2037B	37	74	14	34	50	78	.85	S2076A	76	152	20	95	-	156	2.80
S2038B	38	76	14	34	50	80	.87	S2080A	80	160	20	98	-	164	3.04
S2039B	39	78	14	34	50	82	.89	S2085A	85	170	20	104	-	174	3.40
S2040B	40	80	14	34	50	84	.91	S2090A	90	180	20	110	-	184	3.85
S2041B	41	82	16	40	60	86	1.05	S2095A	95	190	20	116	-	194	4.34
S2042B	42	84	16	40	60	88	1.10	S20100A	100	200	20	122	-	204	4.85
S2043B	43	86	16	40	60	90	1.15	S20110A	110	220	20	134	-	224	5.80
S2044B	44	88	16	40	60	92	1.20	S20114A	114	228	20	140	-	232	6.30
S2045B	45	90	16	40	60	94	1.25	S20120A	120	240	20	148	-	244	6.95
S2046B	46	92	16	40	60	96	1.30	S20127A	127	254	20	157	-	258	7.90
S2047B	47	94	16	40	60	98	1.35								

2.5 Mod Spur Gears

Cat. No.	No. Teeth	Pitch Dia. dp	Min Bore d	Max. Bore	Hub C	Outside Dia. D	Weight kg	Cat. No.	No. Teeth	Pitch Dia. dp	Min Bore d	Max. Bore	Hub C	Outside Dia. D	Weight kg
S2512B	12	30.0	10	14	22	35.0	.16	S2544B	44	110.0	20	46	70	115.0	2.22
S2513B	13	32.5	10	16	25	37.5	.20	S2545B	45	112.5	20	46	70	117.5	2.31
S2514B	14	35.0	10	19	28	40.0	.28	S2546B	46	115.0	20	46	70	120.0	2.39
S2515B	15	37.5	10	20	30	42.5	.36	S2547B	47	117.5	20	54	80	122.5	2.62
S2516B	16	40.0	12	21	32	45.0	.37	S2548B	48	120.0	20	54	80	125.0	2.71
S2517B	17	42.5	12	24	35	47.5	.38	S2549B	49	122.5	20	54	80	127.5	2.81
S2518B	18	45.0	12	24	35	50.0	.40	S2550B	50	125.0	20	54	80	130.0	2.90
S2519B	19	47.5	12	24	35	52.5	.42	S2551B	51	127.5	20	54	80	132.5	3.00
S2520B	20	50.0	14	27	40	55.0	.50	S2552B	52	130.0	20	60	90	135.0	3.25
S2521B	21	52.5	14	27	40	57.5	.53	S2553B	53	132.5	20	60	90	137.5	3.35
S2522B	22	55.0	14	30	45	60.0	.57	S2554B	54	135.0	20	60	90	140.0	3.46
S2523B	23	57.5	14	30	45	62.5	.60	S2555B	55	137.5	20	60	90	142.5	3.57
S2524B	24	60.0	14	30	45	65.0	.68	S2556B	56	140.0	20	67	100	145.0	3.84
S2525B	25	62.5	14	34	50	67.5	.78	S2557B	57	142.5	20	67	100	147.5	3.90
S2526B	26	65.0	14	34	50	70.0	.82	S2558B	58	145.0	20	67	100	150.0	4.07
S2527B	27	67.5	14	34	50	72.5	.87	S2559B	59	147.5	20	67	100	152.5	4.18
S2528B	28	70.0	14	34	50	75.0	.90	S2560B	60	150.0	20	67	100	155.0	4.39
S2529B	29	72.5	14	34	50	77.5	.95	S2565A	65	162.5	20	100	-	167.5	4.00
S2530B	30	75.0	16	36	55	80.0	1.10	S2570A	70	175.0	20	108	-	180.0	4.85
S2531B	31	77.5	16	36	55	82.5	1.15	S2572A	72	180.0	20	110	-	185.0	5.05
S2532B	32	80.0	16	36	55	85.0	1.21	S2575A	75	187.5	20	115	-	192.5	5.33
S2533B	33	82.5	16	36	55	87.5	1.27	S2576A	76	190.0	20	117	-	195.0	5.50
S2534B	34	85.0	16	36	55	90.0	1.30	S2580A	80	200.0	25	123	-	205.0	6.02
S2535B	35	87.5	16	40	60	92.5	1.43	S2585A	85	212.5	25	131	-	217.5	6.90
S2536B	36	90.0	16	40	60	95.0	1.51	S2590A	90	225.0	25	140	-	230.0	7.71
S2537B	37	92.5	16	40	60	97.5	1.58	S2595A	95	237.5	25	148	-	242.5	8.60
S2538B	38	95.0	16	40	60	100.0	1.68	S25100A	100	250.0	25	156	-	255.0	9.50
S2539B	39	97.5	16	40	60	102.5	1.73	S25110A	110	275.0	25	172	-	280.0	11.56
S2540B	40	100.0	20	46	70	105.0	1.80	S25114A	114	285.0	25	178	-	290.0	12.40
S2541B	41	102.5	20	46	70	107.5	1.97	S25120A	120	300.0	25	188	-	305.0	13.87
S2542B	42	105.0	20	46	70	110.0	2.05	S25127A	127	317.5	25	200	-	322.5	15.40
S2543B	43	107.5	20	46	70	112.5	2.14								

Standard Spur Gears



3.0 Mod Spur Gears

Cat. No.	No. Teeth	Pitch Dia. dp	Min Bore d	Max. Bore	hub \varnothing C	Outside Dia. D	Weight kg	Cat. No.	No. Teeth	Pitch Dia. dp	Min Bore d	Max. Bore	hub \varnothing C	Outside Dia. D	Weight kg
S3012B	12	36	12	16	25	42	.27	S3040B	40	120	20	54	80	126	3.23
S3013B	13	39	12	16	25	45	.30	S3041B	41	123	20	60	90	129	3.67
S3014B	14	42	12	20	30	48	.35	S3042B	42	126	20	60	90	132	3.81
S3015B	15	45	12	24	35	51	.45	S3043B	43	129	20	60	90	135	3.95
S3016B	16	48	15	26	38	54	.55	S3044B	44	132	20	60	90	138	4.02
S3017B	17	51	15	28	42	57	.65	S3045B	45	135	20	60	90	141	4.15
S3018B	18	54	15	30	45	60	.75	S3046B	46	138	20	60	90	144	4.30
S3019B	19	57	15	30	45	63	.82	S3047B	47	141	20	60	90	147	4.45
S3020B	20	60	15	30	45	66	.90	S3048B	48	144	20	65	100	150	4.85
S3021B	21	63	15	30	45	69	.96	S3050A	50	150	25	92	-	156	4.00
S3022B	22	66	15	34	50	72	1.08	S3052A	52	156	25	96	-	162	4.30
S3023B	23	69	15	34	50	75	1.16	S3055A	55	165	25	102	-	171	4.85
S3024B	24	72	16	34	50	78	1.22	S3057A	57	171	25	106	-	177	5.20
S3025B	25	75	16	40	60	81	1.30	S3060A	60	180	25	112	-	186	5.80
S3026B	26	78	16	40	60	84	1.40	S3065A	65	195	25	125	-	201	6.80
S3027B	27	81	16	40	60	87	1.50	S3070A	70	210	25	128	-	216	7.90
S3028B	28	84	16	40	60	90	1.63	S3072A	72	216	25	132	-	222	8.40
S3029B	29	87	16	40	60	93	1.76	S3075A	75	225	25	138	-	231	9.10
S3030B	30	90	16	40	60	96	1.90	S3076A	76	228	25	140	-	234	9.40
S3031B	31	93	20	46	70	99	2.00	S3080A	80	240	25	148	-	246	10.40
S3032B	32	96	20	46	70	102	2.12	S3085A	85	255	25	153	-	261	11.90
S3033B	33	99	20	46	70	105	2.25	S3090A	90	270	25	163	-	276	13.20
S3034B	34	102	20	46	70	108	2.37	S3095A	95	285	25	174	-	291	14.95
S3035B	35	105	20	46	70	111	2.50	S30100A	100	300	25	185	-	306	16.45
S3036B	36	108	20	46	70	114	2.63	S30110A	110	330	25	195	-	336	20.00
S3037B	37	111	20	54	80	117	2.86	S30114A	114	342	25	205	-	346	21.50
S3038B	38	114	20	54	80	120	2.98	S30120A	120	360	25	215	-	366	23.70
S3039B	39	117	20	54	80	123	3.10	S30127A	127	381	25	230	-	387	26.74

4.0 Mod Spur Gears

Cat. No.	No. Teeth	Pitch Dia. dp	Min Bore d	Max. Bore	hub \varnothing C	Outside Dia. D	Weight kg	Cat. No.	No. Teeth	Pitch Dia. dp	Min Bore d	Max. Bore	hub \varnothing C	Outside Dia. D	Weight kg
S4012B	12	48	14	24	35	56	.60	S4035B	35	140	20	54	80	148	5.40
S4013B	13	52	14	27	40	60	.75	S4036B	36	144	20	54	80	152	5.70
S4014B	14	56	14	30	45	64	.90	S4038A	38	152	25	90	-	160	5.54
S4015B	15	60	14	30	45	68	1.05	S4040A	40	160	25	95	-	168	6.00
S4016B	16	64	15	34	50	72	1.18	S4045A	45	180	25	108	-	188	7.70
S4017B	17	68	15	34	50	76	1.25	S4048A	48	192	25	116	-	200	8.70
S4018B	18	72	15	34	50	80	1.40	S4050A	50	200	25	122	-	208	9.71
S4019B	19	76	15	40	60	84	1.60	S4052A	52	208	25	127	-	216	10.51
S4020B	20	80	15	40	60	88	1.80	S4055A	55	220	25	135	-	228	11.60
S4021B	21	84	20	46	70	92	2.20	S4057A	57	228	25	140	-	236	12.70
S4022B	22	88	20	46	70	96	2.30	S4060A	60	240	25	148	-	248	13.80
S4023B	23	92	20	50	75	100	2.50	S4065A	65	260	25	161	-	268	16.50
S4024B	24	96	20	50	75	104	2.70	S4070A	70	280	25	175	-	288	18.25
S4025B	25	100	20	50	75	108	2.90	S4075A	75	300	25	188	-	308	22.80
S4026B	26	104	20	50	75	112	3.10	S4076A	76	304	25	190	-	312	22.95
S4027B	27	108	20	50	75	116	3.35	S4080A	80	320	25	200	-	328	25.10
S4028B	28	112	20	50	75	120	3.50	S4085A	85	340	25	214	-	348	28.00
S4029B	29	116	20	50	75	124	3.75	S4090A	90	360	25	227	-	368	31.25
S4030B	30	120	20	50	75	128	3.95	S4095A	95	380	25	240	-	388	35.20
S4031B	31	124	20	54	80	132	4.30	S40100A	100	400	25	254	-	408	39.00
S4032B	32	128	20	54	80	136	4.50	S40110A	110	440	25	280	-	448	47.60
S4033B	33	132	20	54	80	140	4.70	S40114A	114	456	25	290	-	464	51.00
S4034B	34	136	20	54	80	144	5.20								

5.0 Mod Spur Gears

Cat. No.	No. Teeth	Pitch Dia. dp	Min Bore d	Max. Bore	hub \varnothing C	Outside Dia. D	Weight kg	Cat. No.	No. Teeth	Pitch Dia. dp	Min Bore d	Max. Bore	hub \varnothing C	Outside Dia. D	Weight kg
S5012B	12	60	16	30	45	70	1.40	S5038A	38	190	30	110	-	200	10.85
S5013B	13	65	16	34	50	75	1.57	S5040A	40	200	30	116	-	210	12.05
S5014B	14	70	20	36	55	80	1.90	S5045A	45	225	30	126	-	235	15.32
S5015B	15	75	20	40	60	85	2.10	S5048A	48	240	30	141	-	250	17.50
S5016B	16	80	20	43	65	90	2.44	S5050A	50	250	30	147	-	260	19.00
S5017B	17	85	20	46	70	95	2.80	S5052A	52	260	30	154	-	270	20.50
S5018B	18	90	20	46	70	100	3.07	S5055A	55	275	30	164	-	285	23.04
S5019B	19	95	20	46	70	105	3.35	S5057A	57	285	30	170	-	295	24.76
S5020B	20	100	20	54	80	110	3.88	S5060A	60	300	30	180	-	310	27.40
S5021B	21	105	20	54	80	115	4.20	S5065A	65	325	30	196	-	335	32.28
S5022B	22	110	25	54	80	120	4.60	S5070A	70	350	30	212	-	360	37.48
S5023B	23	115	25	60	90	125	5.04	S5075A	75	375	30	228	-	385	43.07
S5024B	24	120	25	60	90	130	5.40	S5076A	76	380	30	230	-	390	44.23
S5025B	25	125	25	60	90	135	5.78	S5080A	80	400	30	243	-	410	49.30
S5026B	26	130	25	67	100	140	6.69	S5085A	85	425	30	260	-	435	55.50
S5027B	27	135	25	67	100	145	6.88	S5090A	90	450	30	275	-	460	62.20
S5028B	28	140	25	67	100	150	7.30	S5095A	95	475	30	290	-	485	69.35
S5029B	29	145	25	67	100	155	7.90	S50100A	100	500	30	305	-	510	76.90
S5030B	30	150	25	67	100	160	8.38	S50110A	110	550	30	340	-	560	96.50
S5032A	32	160	25	90	-	170	8.00	S50114A	114	570	30	350	-	580	103.55
S5035A	35	175	25	100	-	185	9.40								

6.0 Mod Spur Gears

Cat. No.	No. Teeth	Pitch Dia. dp	Min Bore d	Max. Bore	hub \varnothing C	Outside Dia. D	Weight kg	Cat. No.	No. Teeth	Pitch Dia. dp	Min Bore d	Max. Bore	hub \varnothing C	Outside Dia. D	Weight kg
S6012B	12	72	-	36	54	84	2.05	S6025B	25	150	-	74	110	162	9.50
S6013B	13	78	-	40	60	90	2.50	S6028A	28	168	25	100	-	180	10.20
S6015B	15	90	-	46	70	102	3.40	S6030A	30	180	25	108	-	192	11.75
S6016B	16	96	-	50	75	108	3.90	S6032A	32	192	25	116	-	204	13.40
S6018B	18	108	-	54	80	120	4.90	S6035A	35	210	25	128	-	222	16.10
S6020B	20	120	-	60	90	132	6.15	S6038A	38	228	25	138	-	240	19.02
S6021B	24	144	-	74	110	156	8.85	S6040A	40	240	25	145	-	252	21.10

Tel +44 121 360 0155

Fax +44 121 325 1079

Email sales@crossmorse.com

Cast Iron Spur Gears and Steel Racks



Cast Iron Spur Gears

Cross+Morse standard cast iron gears are manufactured in 7 pitch sizes from 2.0 Mod to 5.0 Mod. They are machined from Grade 200 iron casting with gears finished to DIN Class 7 standard. All spur gears are with 20 degree pressure angle and same face widths as the standard steel gears of the same pitch, enabling correct operation with these steel pinions. Cast iron gears are an ideal choice for lower torque, slow speed (max. pitch line speed 2.5 m/s) drives, offering lower cost and weight to equivalent machined steel gear. Their reduced weight makes them popular on mobile plant.



Cat. No.	Mod.	No. Teeth	Pitch Dia. dp	Min. Bore d	Max. Bore	Width B	Hub C	O.D. D	Weight kg
S2050C	2.0 Mod	50	100	15	25	20	40	104	0.85
S2545C	2.5 Mod	45	112.5	18	30	25	50	117.5	1.45
S2550C	2.5 Mod	50	125	18	30	25	50	130	1.70
S3045C	3.0 Mod	45	135	20	30	30	50	141	2.30
S3060C	3.0 Mod	60	180	20	30	30	50	186	3.60
S3535C	3.5 Mod	35	122.5	20	36	35	60	129.5	2.45
S3540C	3.5 Mod	40	140	20	36	35	60	147	3.15
S3545C	3.5 Mod	45	157.5	20	36	35	60	163.5	4.10
S3550C	3.5 Mod	50	175	20	36	35	60	182	4.70
S4030C	4.0 Mod	30	120	25	42	40	70	128	2.80
S4035C	4.0 Mod	35	140	25	42	40	70	148	3.60
S4040C	4.0 Mod	40	160	25	42	40	70	168	4.70
S4045C	4.0 Mod	45	180	25	42	40	70	188	5.40
S4050C	4.0 Mod	50	200	25	42	40	70	208	7.10
S4530C	4.5 Mod	30	135	25	42	45	70	144	4.00
S4535C	4.5 Mod	35	157.5	25	42	45	70	166.5	5.10
S4540C	4.5 Mod	40	180	25	42	45	70	189	6.45
S4545C	4.5 Mod	45	202.5	25	42	45	70	211.5	7.95
S4550C	4.5 Mod	50	225	25	42	45	70	234	9.70
S5030C	5.0 Mod	30	150	30	48	50	80	160	5.10
S5035C	5.0 Mod	35	175	30	48	50	80	185	6.85
S5040C	5.0 Mod	40	200	30	48	50	80	210	8.60
S5050C	5.0 Mod	50	250	30	48	50	80	260	12.45

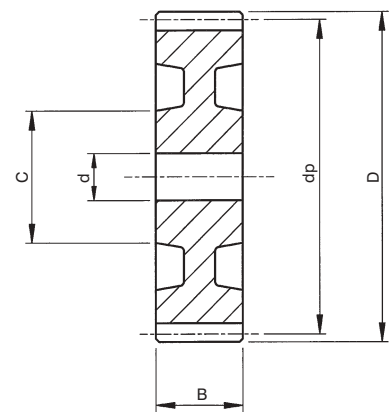

Gears stocked pilot bored can be supplied finish bored and keywayed.

All dimensions in mm.

Steel Racks

Cross+Morse standard gear racks are manufactured in medium carbon steel suitable for induction or flame hardening if required. The spur gears have identical face width. The designer is free to select any combination of standard spur gear and rack of same pitch to obtain "off the shelf" rack and pinion sets. These provide the ideal method to convert rotary into linear motion for table drives etc. or linear to rotary motion as in feeds. In addition to the standard range of racks special constructions can be provided with pitch size up to 16 mod.



Cat. No.	Pitch Module	Width B	Overall Height h	Height to Pitch Line hp	Length L	Approx. Weight Kg.
R1005	1	15	15	14	500	0.82
R1010		15	15	14	1000	1.65
R1020		15	15	14	2000	3.05
R1505	1.5	17	17	15.5	500	1.08
R1510		17	17	15.5	1000	2.07
R1520		17	17	15.5	2000	4.30
R2005	2	20	20	18	500	1.40
R2010		20	20	18	1000	2.82
R2020		20	20	18	2000	5.10
R2505	2.5	25	25	22.5	500	2.00
R2510		25	25	22.5	1000	4.00
R2520		25	25	22.5	2000	7.40
R3005	3	30	30	27	500	3.10
R3010		30	30	27	1000	6.20
R3020		30	30	27	2000	11.50
R4005	4	40	40	36	500	5.50
R4010		40	40	36	1000	11.00
R4020		40	40	36	2000	20.40
R5005	5	50	50	45	500	7.92
R5010		50	50	45	1000	15.90
R5020		50	50	45	2000	29.40
R6005	6	60	60	54	500	12.15
R6010		60	60	54	1000	24.30
R6020		60	60	54	2000	50.20

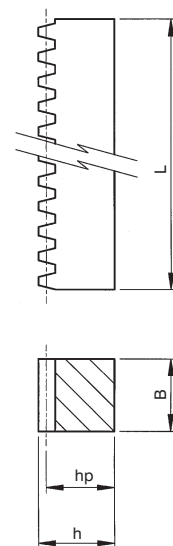

Racks can be supplied modified to enable easy mounting by addition of plain or tapped holes.